



Project _____

Item # _____

Quantity _____

Toast-Qwik® Electric Conveyor Toasters

Models: TQ-10, -400, -405, -400BA, -400H

The Hatco Toast-Qwik® is an economical conveyor toaster with fast, dependable and versatile toasting. These toasters utilize conveyor speed, not temperature to determine toasting color.

Standard features

- Patented ColorGuard sensing system assures toast uniformity. (excludes TQ-10)
- Power save mode with indicator light saves energy and money during slow periods
- Efficient design of front or rear discharge allows Toast-Qwik to be placed where it is most convenient – for sending product to operator side or customer/server
- BA models toast one side only and are for bagels and buns only, cut side up
- Opening height is 2" (5 mm) and for H models is 3" (8 mm)
- Insulation and an interior fan provide cool surface temperatures
- TQ-10 has a durable painted steel top and aluminized steel construction
- Toast storage area keeps bread warm and dry
- Permanently lubricated ball bearing motor and heating elements guaranteed against burnout and breakage for two years



Options (available at time of purchase only)

- Automatic Power Save Mode (TQ-400 Series only)

Accessories

- Additional extended feed guide (Add 3" (76 mm))
- Security Package
- 20 Amp Receptacle: 125V (NEMA 5-20R)
- 20 Amp Receptacle: 250V (NEMA 6-20R)
- 30 Amp Receptacle: 250V (NEMA 6-30R)

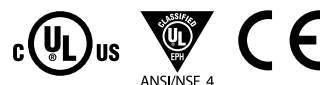

HATCO CORPORATION | P.O. Box 340500 Milwaukee, WI 53234-0500 U.S.A. | (800) 558-0607 | (414) 671-6350
 Fax: (800) 543-7521 | Int'l. Fax: (414) 671-3976 | www.hatcocorp.com | email: equipsales@hatcocorp.com



Toast Qwik® Electric Conveyor Toasters

Models: TQ-10, -400, -405, -400BA, -400H

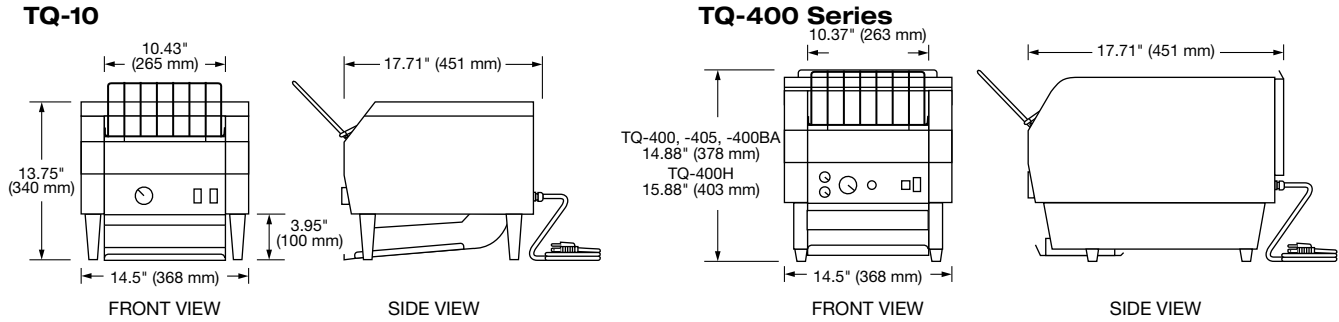

SPECIFICATIONS Toast Qwik Conveyor Toasters

■ The shaded areas contain electrical information for International models only

| Model | Dimensions (Width x Depth x Height*) | Volts | Hertz | Phase | Watts | Amps | Plug | Ship Weight* |
|----------|---|--------------|-----------|--------|-----------|------------------------------|------------------------------|-----------------|
| TQ-10 | 14.5" x 17.71" x 13.75" (368 x 451 x 340 mm) | 120 | 60 | Single | 1800 | 15.0 | NEMA 5-15P* | 42 lbs. (19 kg) |
| | | 208 | | | 1830 | 8.8 | NEMA 6-15P | |
| | | 240 | | | 7.6 | NEMA 6-15P | | |
| | | 200 | 2070 | | 10.4 | AS 3112 | | |
| | | 220-230 (CE) | 1866-2048 | | 8.5-8.9 | CEE 7/7, BS-1363, or AS 3112 | | |
| | | 230-240 (CE) | 2048-2221 | | 8.9-9.3 | | | |
| TQ-400 | 14.5" x 17.71" x 14.88" (368 x 451 x 378 mm) | 120 | 60 | Single | 1790 | 14.9 | NEMA 5-15P* | 46 lbs. (21 kg) |
| | | 208 | | | 2230 | 10.7 | NEMA 6-15P | |
| | | 240 | | | 9.3 | NEMA 6-15P | | |
| | | 200 | 2064 | | 10.3 | AS 3112 | | |
| | | 220-230 (CE) | 1860-2030 | | 8.5-8.8 | CEE 7/7, BS-1363, or AS 3112 | | |
| | | 230-240 (CE) | 2030-2210 | | 8.8-9.2 | | | |
| TQ-405 | 14.5" x 17.71" x 14.88" (368 x 451 x 378 mm) | 220-230 (CE) | 50-60 | Single | 2131-2330 | 9.7-10.1 | CEE 7/7, BS-1363, or AS 3112 | 46 lbs. (21 kg) |
| | | 230-240 (CE) | | | 2030-2210 | 8.8-9.2 | | |
| TQ-400H | 14.5" x 17.71" x 15.88" (368 x 451 x 403 mm) Tray extends 2.5" (64 mm) in rear | 208 | 60 | Single | 2230 | 10.7 | NEMA 6-15P | 46 lbs. (21 kg) |
| | | 240 | | | 9.3 | NEMA 6-15P | | |
| | | 200 | 2064 | | 10.3 | AS 3112 | | |
| | | 220-230 (CE) | 2131-2330 | | 9.7-10.1 | CEE 7/7, BS-1363, or AS 3112 | | |
| | | 230-240 (CE) | 2030-2210 | | 8.8-9.2 | | | |
| TQ-400BA | 14.5" x 17.71" x 14.88" (368 x 451 x 378 mm) | 120 | 60 | Single | 1780 | 14.8 | NEMA 5-15P* | 46 lbs. (21 kg) |
| | | 208 | | | 1880 | 9.0 | NEMA 6-15P | |
| | | 240 | | | 7.8 | NEMA 6-15P | | |
| | | 200 | 1848 | | 9.2 | AS 3112 | | |
| | | 220-230 (CE) | 1765-1930 | | 8.0-8.4 | CEE 7/7, BS-1363, or AS 3112 | | |
| | | 230-240 (CE) | 1930-2100 | | 8.4-8.8 | | | |

* TQ-400 and -400BA, add 2.5" (64 mm) to depth if using tray extension in rear. Height includes legs.

* Shipping weight includes packaging.

* NEMA 5-20P for Canada.

CORD LOCATION

Lower right corner on back of unit.

PLUG CONFIGURATIONS

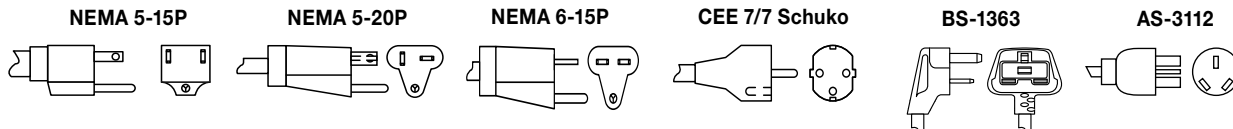

PRODUCT SPECS Conveyor Toasters

The electric Conveyor Toaster with patented Color Guard (excludes TQ-10) shall be a Hatco model ... as manufactured by the Hatco Corporation, Milwaukee, WI 53234 U.S.A. The toaster shall have the capacity to toast up to ... pieces per minute and it shall be rated at ... kW, ... volts, single phase. The toaster shall be of stainless steel design and shall include a front mounted control panel with a toast selector knob, variable speed control knob, and an aluminum toast collector pan (excluding TQ-10).

The toaster will have multiple metal sheathed heating elements and an impedance protected motor. It shall be complete with factory attached UL listed 4' (1219 mm) cord and plug.

Comes with 24/7 parts and service assistance (U.S. and Canada only).

HATCO CORPORATION | P.O. Box 340500 Milwaukee, WI 53234-0500 U.S.A. | (800) 558-0607 | (414) 671-6350

Fax: (800) 543-7521 | Int'l. Fax: (414) 671-3976 | www.hatcocorp.com | email: equipsales@hatcocorp.com