

Kabel 1 - diflex Classic 4G2,5qmm	013.00022	Einbau-Induktionsherd 1-Induktion SKW BIIEG BIPS ESRTI	 Berner-Kochsysteme GmbH & Co. KG Sudetenstraße 5 D-87471 Durach Tel:+49(0)831/697247-0, Fax:-15 bernerkoch@induktion.de www.induktion.de	Änderung				
Kabel 2 - diflex Classic 110CY 4G2,5qmm	013.00035			a				
				b				
		c						
FI-F3 - Generatorsicherung BI64	300121	Version	1.3					
Schaltplan BI1-1/43			Blatt	1/2	Datum	08.07.15	Zeichner	Hänel

Jumperstellungen:

SW1: 4 u. 5 Leistungseinstellung

SW1: 6

Warmhaltefunktion = Ein A
 Warmhaltefunktion = Aus B

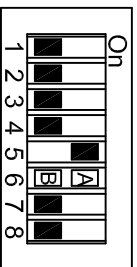

SW1

Jumperstellungen:

SW3: 1

Frequenz = ein (Einzelkochstelle)
 Pulse = aus (Mehrere Kochstellen)

SW3: 3 u.4
 Pfannenempfindlichkeit

SW3: 5,6,7 u. 8 Spulentypen
 Ø230;Ø260.Wok: 5,6,7,8 = Off
 Ø280: 5,6,7 = Off, 8 = On
 Q270: 5,6,8 = Off, 7 = On
 280x280F: 5,7,8 = Off, 6 = On
 250x460GN: 5,8 = Off, 6,7 = On

A = On B = Off

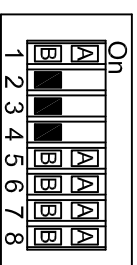

SW3

Version T = getrennt

Jumperstellungen:

SW1.1: PT1000A On/Off

SW1.2: PT1000B On/Off

SW1.3: On=letzte Anzeige;
 Off=Einzel- o.weitere Anzeige

SW1.4: Anzeige gedreht

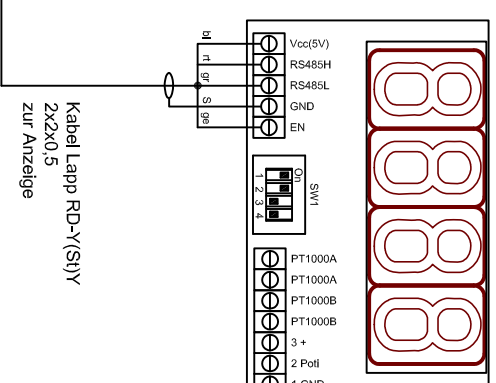
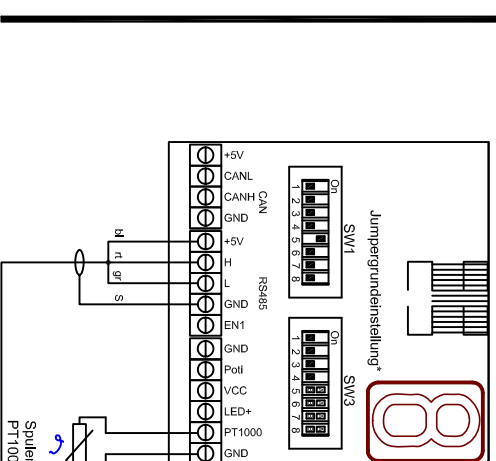
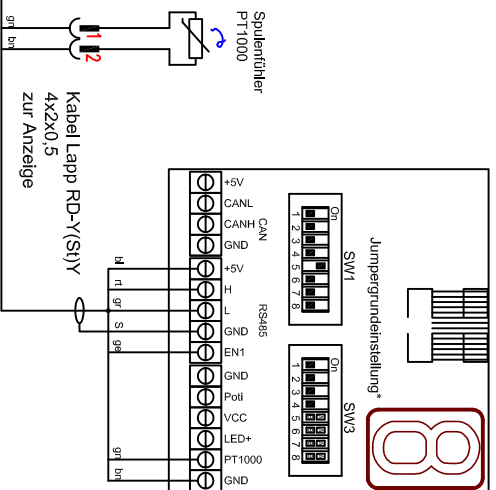
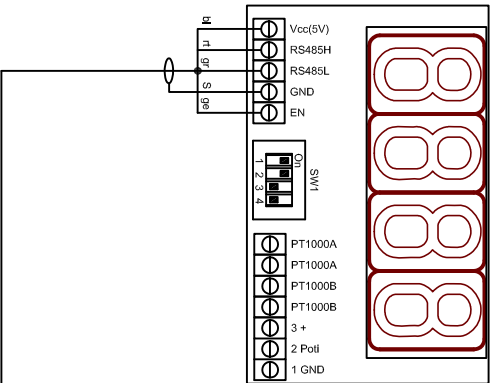

Version T = Modul

Jumperstellungen:

SW1.1: PT1000A On/Off

SW1.2: PT1000B On/Off

SW1.3: On=letzte Anzeige;
 Off=Einzel- o.weitere Anzeige

SW1.4: Anzeige gedreht

Spuleneinstellungen BIPS
 Generator 3x400V / 5,0kW
 Vers. 4.xx ESRTI

Berner Kochsysteme GmbH&Co.KG
 Sudetenstraße 5
 D-87471 Durach
 Tel.: +49(0)831/697247-0, Fax: -15
 berner@induktion.de
 www.induktion.de

Änderung	a	b	c	d	Version:	1.0
BilH					Datum	Name
1/1					10.04.19	Hänel