

Digitalsteuerung lose anhängend,  
Verbindungsleitung ca. 1m

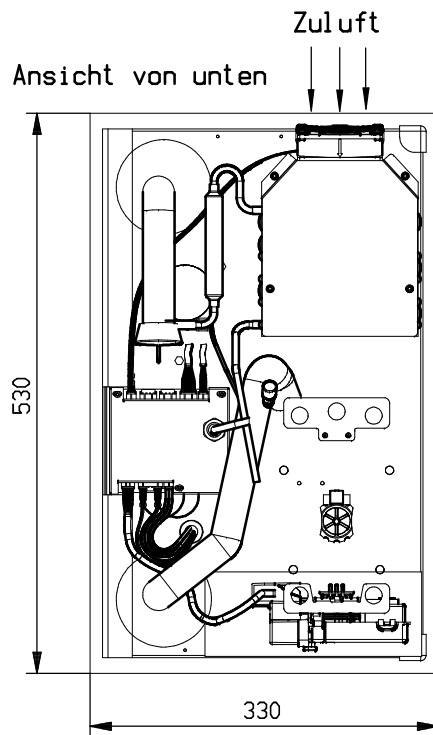
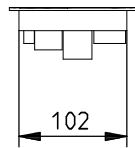
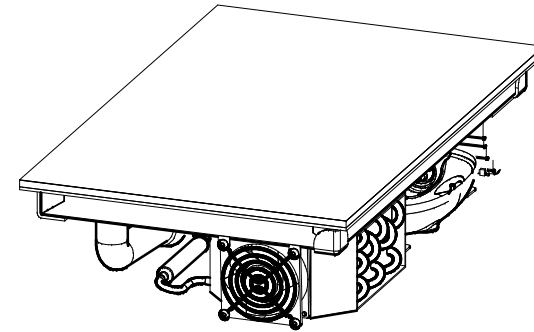
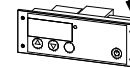

Elektrische Zuleitung  
ca. 1,6m steckerartig

Hinweis:

- Elektrischer Anschluss: 230 V / 0,85 kW
- Kühlmittel: R600a / Kälteleistung: 70 W
- Temperaturbereich -5 bis +15 °C, stufenlos regelbar
- Absatz in Arbeitsplatte: 340 x 540 mm / 10 mm tief
- Ausschnittmaß für Kalt-Platte: 311 x 511 mm
- Ausschnittmaß für Bedieneinheit: 102,5 x 35 mm
- Mindesteinbauhöhe 160 mm

				Format:	Maßstab: 1:5	Werkstoff:	Blechdicke: mm																										
				<table border="1"> <tr> <td>Erstellt</td> <td>01.12.2017</td> <td>Technik2</td> <td rowspan="3">                 Teilebenennung: Kaltplatte CK 330                  Teilebenennung2: GN 1/1 CNS/steckerfertig                  L-B-H: 330.00 - 530.00 - 160.00             </td> </tr> <tr> <td>Gepüft</td> <td>13.02.2018</td> <td>Technik2</td> </tr> <tr> <td>Freigabe</td> <td>13.02.2018</td> <td>Technik2</td> </tr> <tr> <td colspan="4">                 Norm:                  Scholl Apparatebau GmbH &amp; Co KG                  Zinziner Weg 4 - 56470 Bad Marienberg                  Telefon ++4902661-9868-0                  Telefax ++4902661-9868-28             </td> <td>Dokumentnummer: ZNR-00108345</td> <td rowspan="2">Blatt: 1</td> </tr> <tr> <td colspan="4"></td> <td>Teilenummer: C6019</td> <td>a</td> </tr> <tr> <td>Index</td> <td>Änderung</td> <td>Datum</td> <td>Name</td> <td>Original:</td> <td colspan="3">Ersatz für:</td> </tr> </table>				Erstellt	01.12.2017	Technik2	Teilebenennung: Kaltplatte CK 330 Teilebenennung2: GN 1/1 CNS/steckerfertig L-B-H: 330.00 - 530.00 - 160.00	Gepüft	13.02.2018	Technik2	Freigabe	13.02.2018	Technik2	Norm: Scholl Apparatebau GmbH & Co KG Zinziner Weg 4 - 56470 Bad Marienberg Telefon ++4902661-9868-0 Telefax ++4902661-9868-28				Dokumentnummer: ZNR-00108345	Blatt: 1					Teilenummer: C6019	a	Index	Änderung	Datum	Name
Erstellt	01.12.2017	Technik2	Teilebenennung: Kaltplatte CK 330 Teilebenennung2: GN 1/1 CNS/steckerfertig L-B-H: 330.00 - 530.00 - 160.00																														
Gepüft	13.02.2018	Technik2																															
Freigabe	13.02.2018	Technik2																															
Norm: Scholl Apparatebau GmbH & Co KG Zinziner Weg 4 - 56470 Bad Marienberg Telefon ++4902661-9868-0 Telefax ++4902661-9868-28				Dokumentnummer: ZNR-00108345	Blatt: 1																												
				Teilenummer: C6019		a																											
Index	Änderung	Datum	Name	Original:	Ersatz für:																												