

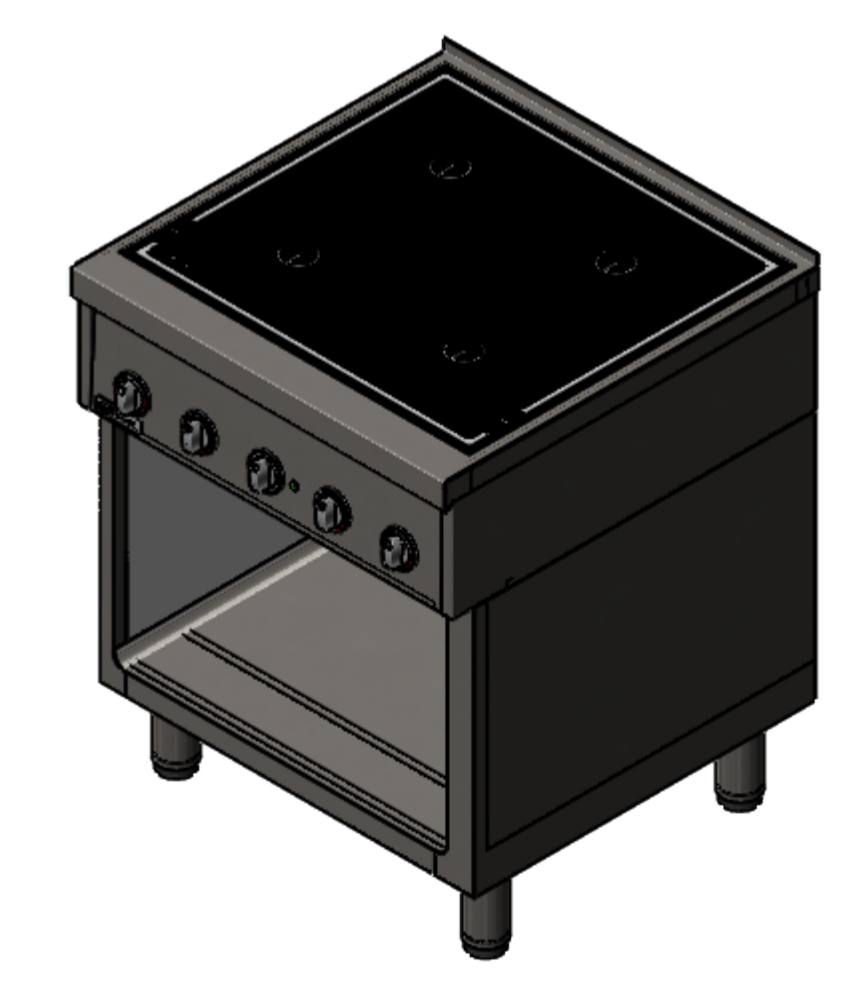

Anschlussschema

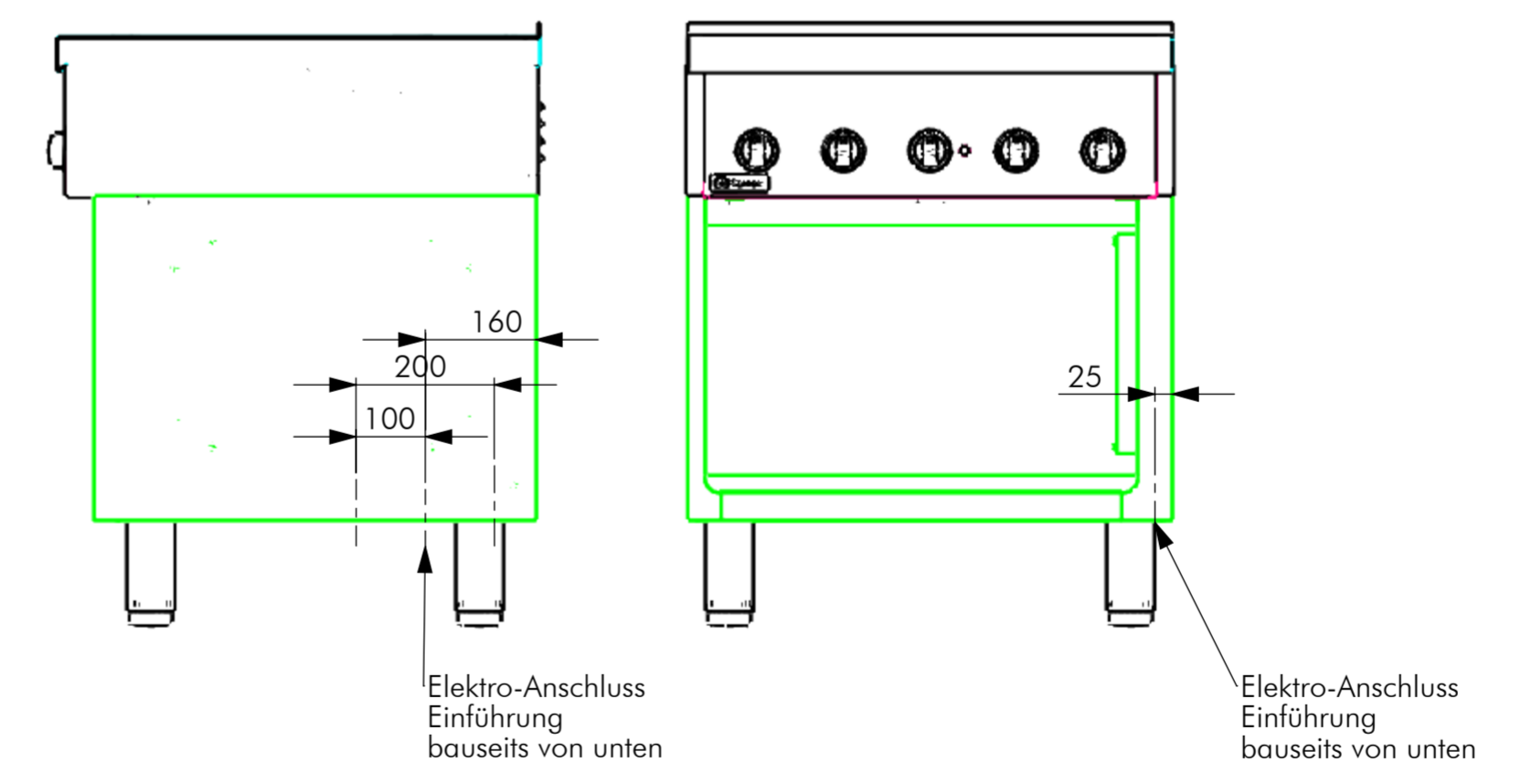

Berner
 Berner-Kochsysteme GmbH & Co.KG
 Sudetenstr.5 D-87471 Durach
 www.induktion.de

GEZEICHNET	NAME	DATUM	SIG.	alle Maße in mm	DATUM	SIG.	INDEX	ÄNDERUNG
GEPRÜFT	Adolf	30.11.2018	MA	Allgemeintoleranz = m	30.11.2018	MA	a	
							b	
							c	
							d	

Material:
 Gewicht: 35725.18g
 BENENNUNG:

Geräteansicht 1

ZEICHNUNGSNR: **BIH4KTDF20**

MASSSTAB: 1:5
 A2

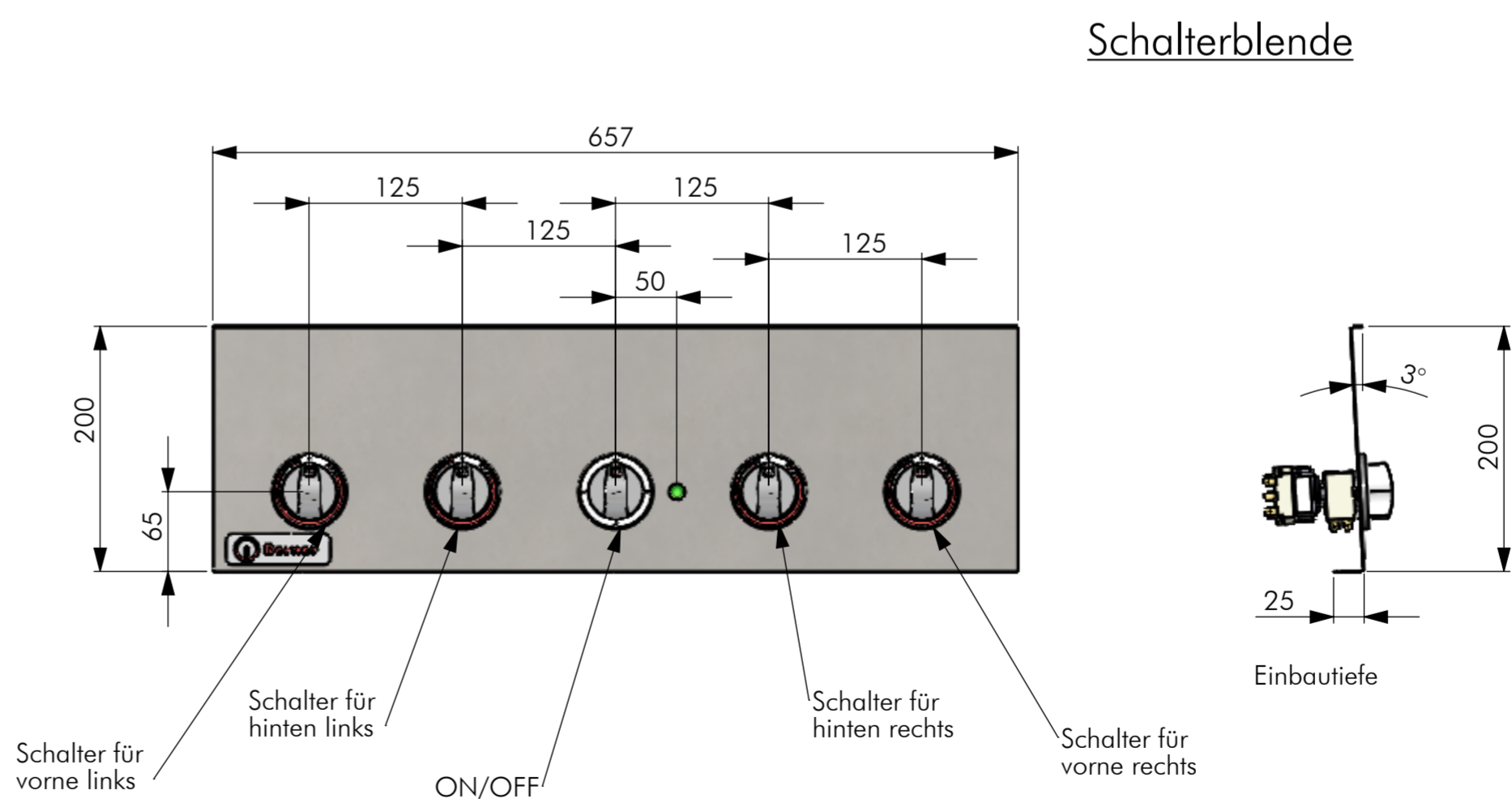
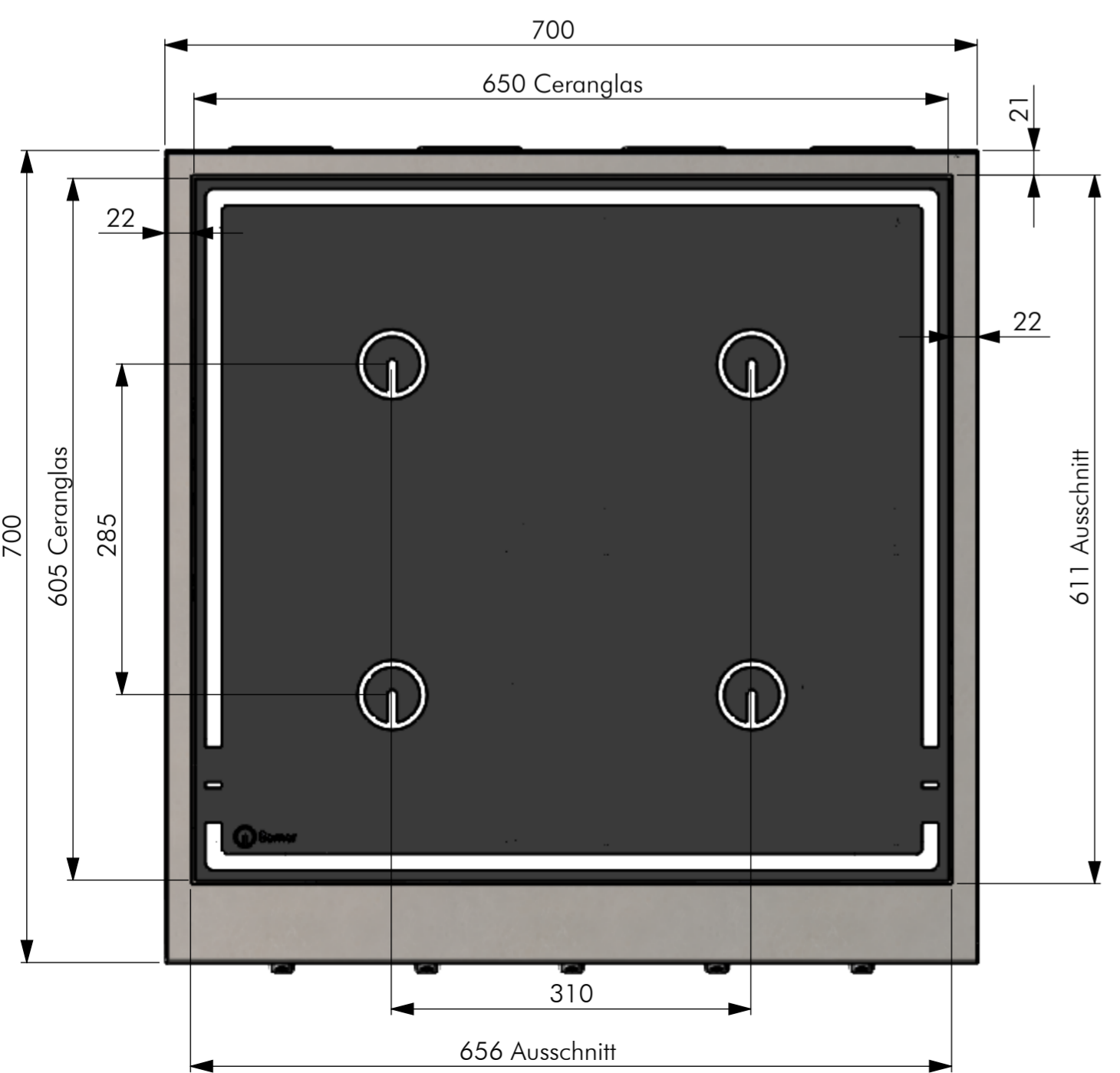
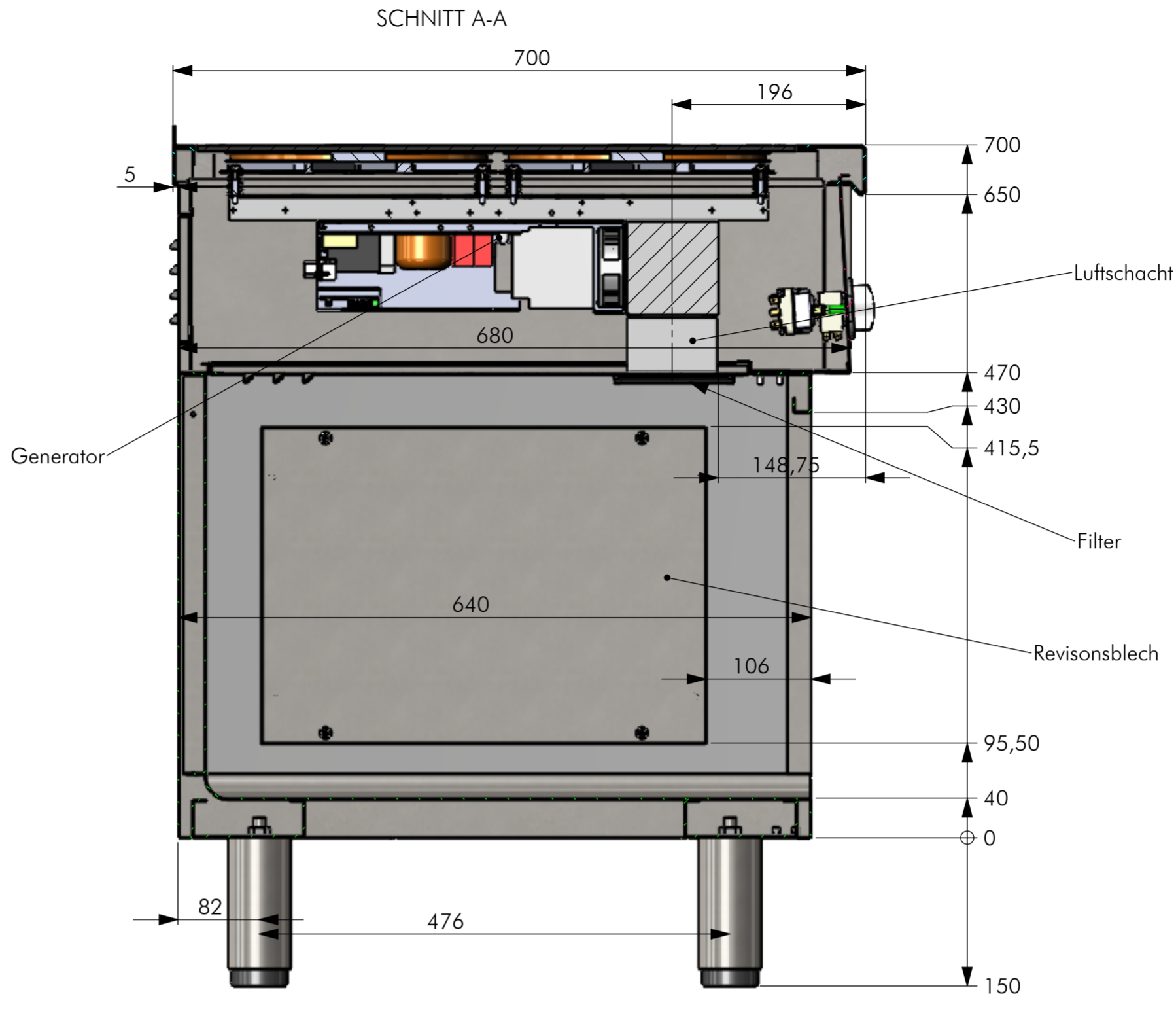
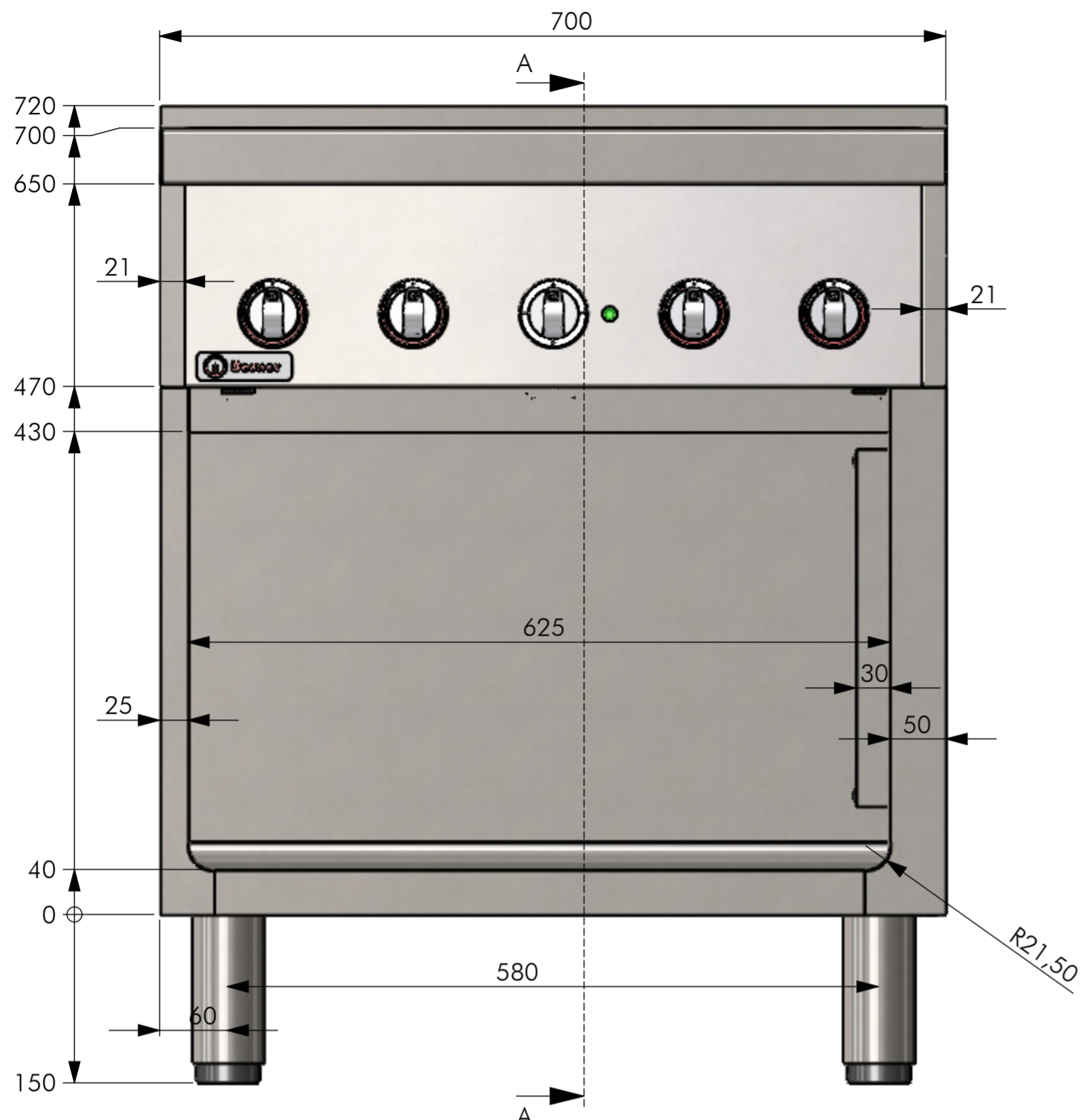

Berner
 Berner-Kochsysteme GmbH & Co.KG
 Sudetenstr. 5 D-87471 Durach
 www.induktion.de

NAME	DATUM	SIG.	alle Maße in mm	DATUM	SIG.	INDEX	ÄNDERUNG
GEZEICHNET	Adolf	30.11.2018	MA	30.11.2018	MA	a	
GEPRÜFT			Allgemeintoleranz = m			b	
						c	
						d	

BENENNUNG: **Geräteansicht 2**

ZEICHNUNGSNR: **BIH4KTDF20**

MASSSTAB: 1:5

BLATT 2 VON 3

Bodenblech

POS-NR.	BENENNUNG	SW-Titel(Title)	MENGE
1	Mittelteil Sys70	Mittelteil	1
2	750508_BIH4KTD-SB	Blende	1
3	System_70-UB-700	Unterbau	1
4	324_2_650x605x6_1210482	Ceranfeld	1
5	Generator BIPDS-Verbau	Generator	2
6	Bobe70	Bodenblech	1
7	100068_Fettfilterrahmen_BIPDS	Rahmen-Fett	2
8	400425	Fettfilter	2
9	700502	Fuss	4
10	OT70	Oberteil	1

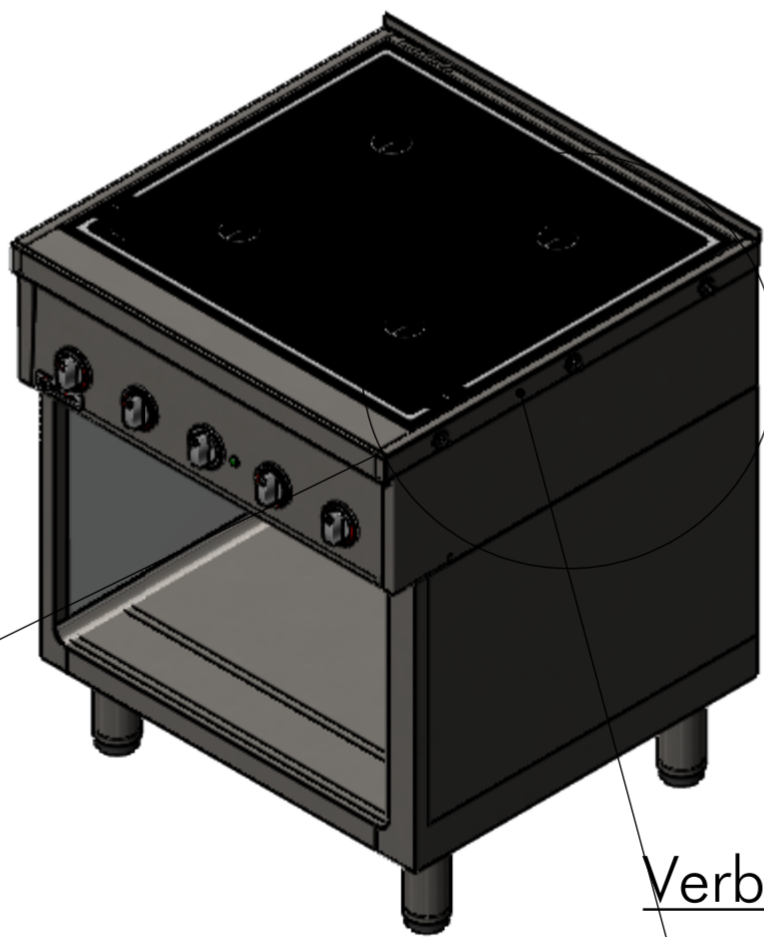
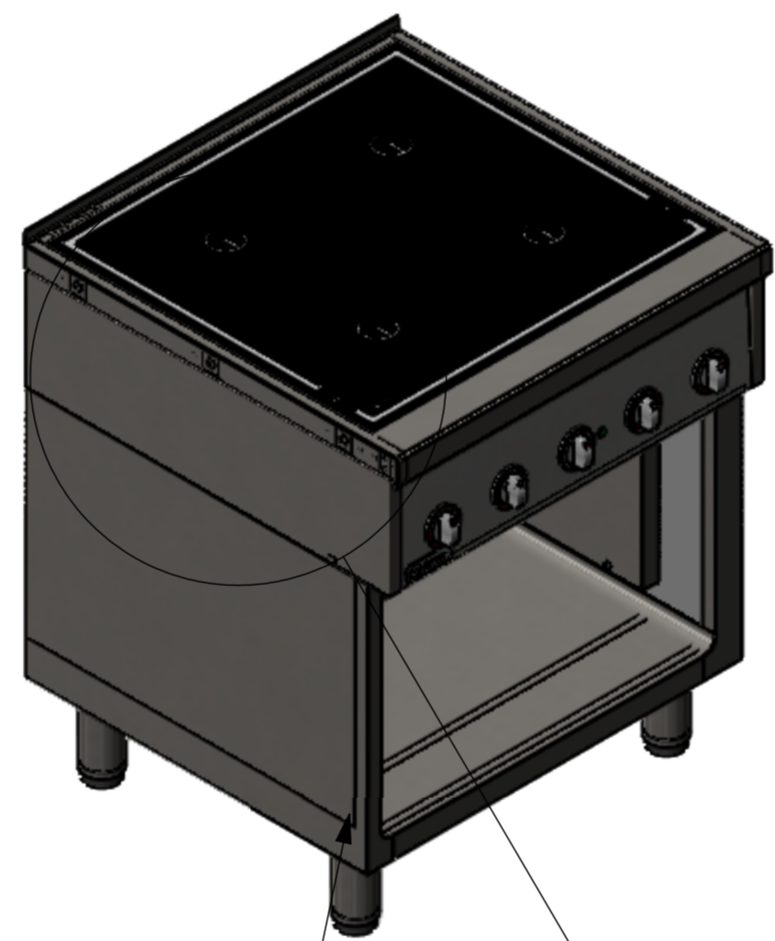
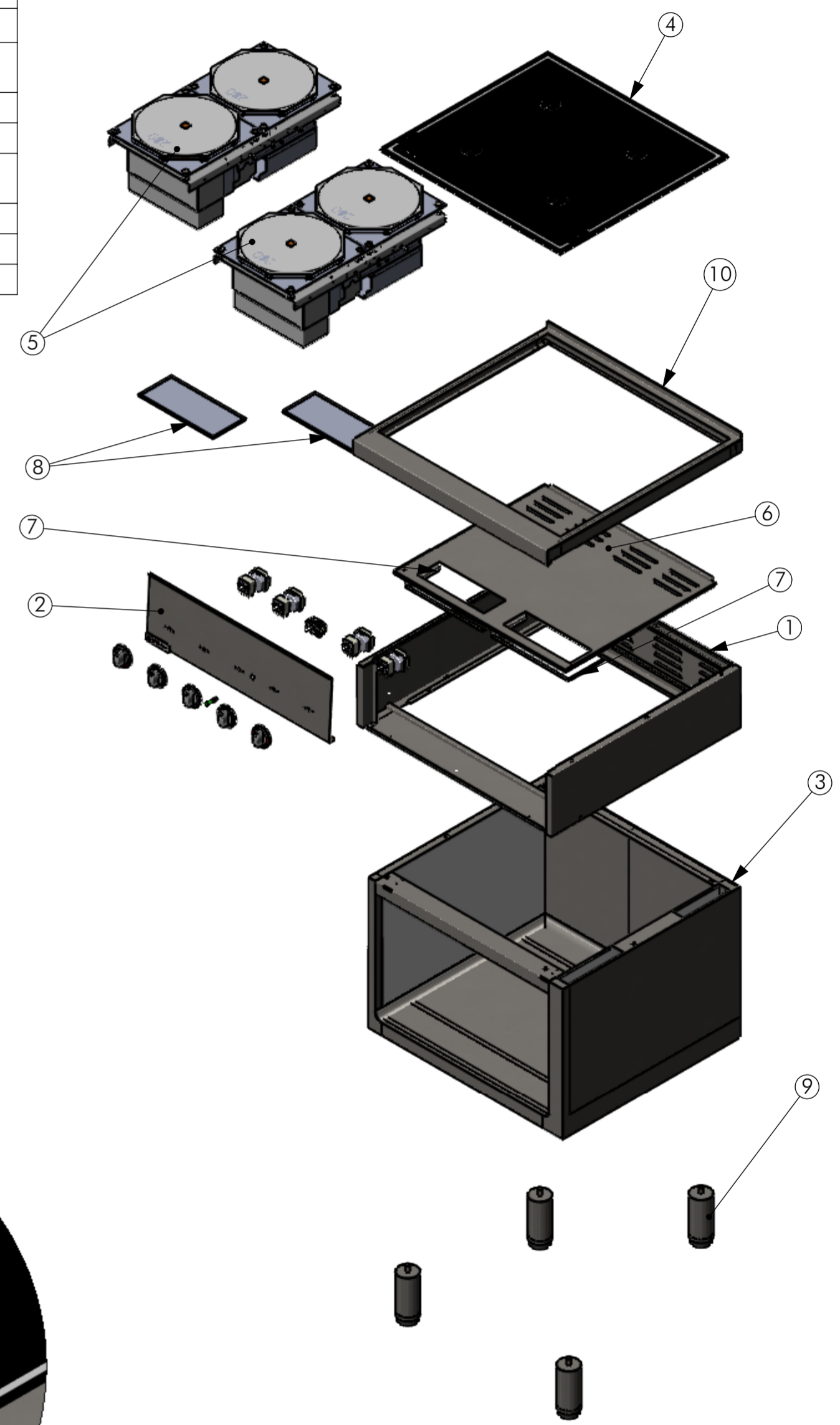
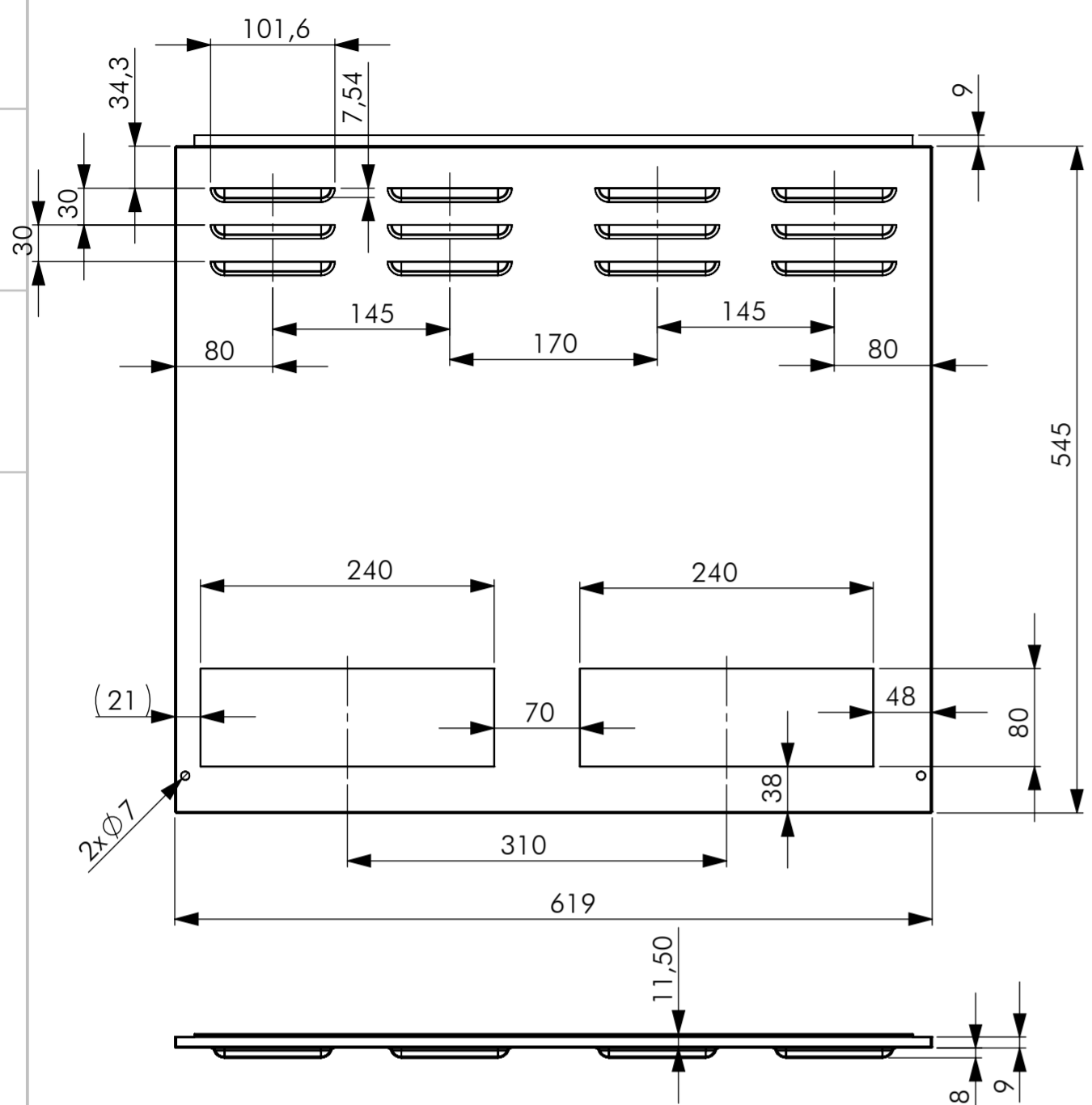

Verbindungsschien- A

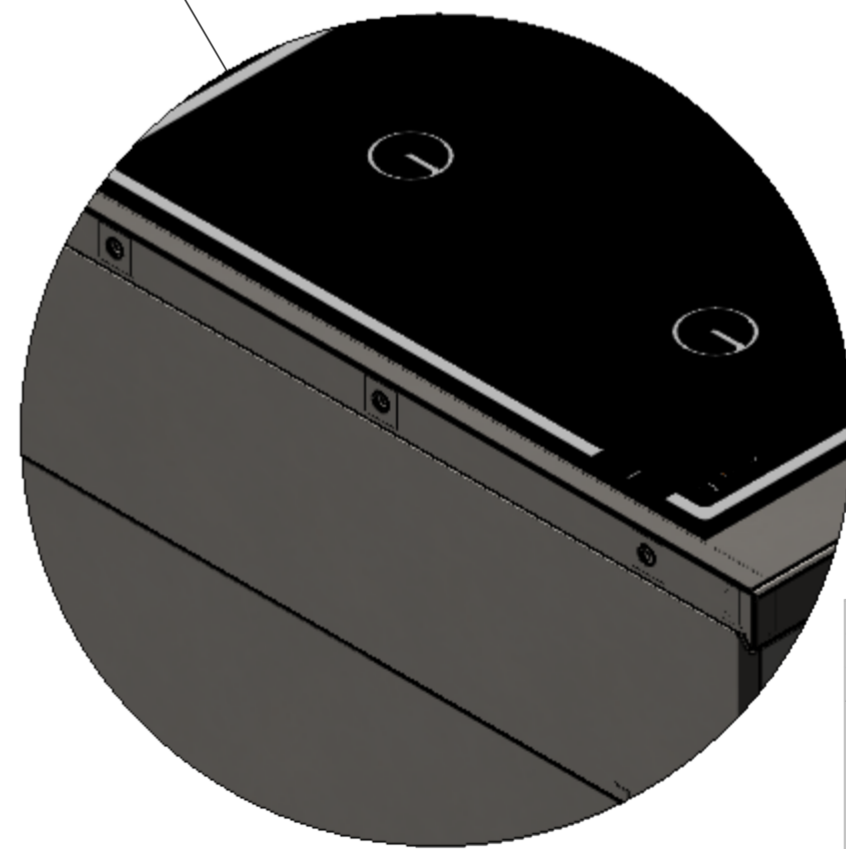

Verbindungsschien- B

Verbindungssystem

Verbindungssystem
Schiene-A
Schiene-B

GEZEICHNET	NAME	DATUM	SIG.	alle Maße in mm	DATUM	SIG.	INDEX	ÄNDERUNG
GEPRÜFT	Adolf	30.11.2018	MA	Allgemeintoleranz = m	30.11.2018	MA	a	
							b	
							c	
							d	

Berner

Berner-Kochsysteme GmbH & Co.KG
Sudetenstr.5 D-87471 Durach
www.induktion.de

BENENNUNG: **Explosionsansicht**

ZEICHNUNGSNR: **BIH4KTDF20**

MASSSTAB 1:5

BLATT 3 VON 3